



**ZHX1203**

***SIR UltraSlim™  
Transceiver (IrMC)***

**Product Specification**

PS016406-1005



This publication is subject to replacement by a later edition. To determine whether a later edition exists, or to request copies of publications, contact:

### **ZiLOG Worldwide Headquarters**

532 Race Street  
San Jose, CA 95126-3432  
Telephone: 408.558.8500  
Fax: 408.558.8300  
[www.ZiLOG.com](http://www.ZiLOG.com)

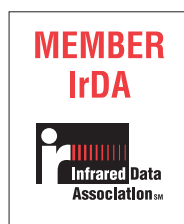

ZiLOG is a registered trademark of ZiLOG Inc. in the United States and in other countries. All other products and/or service names mentioned herein may be trademarks of the companies with which they are associated.

### **Document Disclaimer**

©2005 by ZiLOG, Inc. All rights reserved. Information in this publication concerning the devices, applications, or technology described is intended to suggest possible uses and may be superseded. ZiLOG, INC. DOES NOT ASSUME LIABILITY FOR OR PROVIDE A REPRESENTATION OF ACCURACY OF THE INFORMATION, DEVICES, OR TECHNOLOGY DESCRIBED IN THIS DOCUMENT. ZiLOG ALSO DOES NOT ASSUME LIABILITY FOR INTELLECTUAL PROPERTY INFRINGEMENT RELATED IN ANY MANNER TO USE OF INFORMATION, DEVICES, OR TECHNOLOGY DESCRIBED HEREIN OR OTHERWISE. Devices sold by ZiLOG, Inc. are covered by warranty and limitation of liability provisions appearing in the ZiLOG, Inc. Terms and Conditions of Sale. ZiLOG, Inc. makes no warranty of merchantability or fitness for any purpose. Except with the express written approval of ZiLOG, use of information, devices, or technology as critical components of life support systems is not authorized. No licenses are conveyed, implicitly or otherwise, by this document under any intellectual property rights.



# Table of Contents

Description .....	1
Features .....	2
Pin Description .....	2
VCC Positive Supply .....	2
GND Ground .....	3
SD Shutdown .....	3
RxD Receive Data .....	3
TxD Transmit Data .....	3
LEDA LED Driver .....	3
TAB Shield Connection .....	3
Application Block Diagrams .....	4
Electrical and Timing Specifications .....	5
ZHX1203 Tape and Reel Specifications .....	8
ZHX1203 Soldering and Cleaning Recommendations .....	9
Reflow Soldering .....	9
Manual Soldering .....	9
Cleaning .....	9
Moisture Prevention Guidelines .....	10
Baking .....	10
Mechanical Drawing .....	11
Ordering Information .....	12
Customer Feedback Form .....	13
Customer Information .....	13
Product Information .....	13
Return Information .....	13
Problem Description or Suggestion .....	13



## List of Figures

Figure 1.	UltraSlim Form . . . . .	1
Figure 2.	ZHX1203 Block Diagram . . . . .	1
Figure 3.	ZHX1203 Application Block Diagrams . . . . .	4
Figure 4.	ZHX1203 Reel Specifications . . . . .	8
Figure 5.	ZHX1203 Tape Specifications . . . . .	8
Figure 6.	ZHX1203 Packaging . . . . .	10
Figure 7.	ZHX1203 Mechanical Drawing . . . . .	11

## List of Tables

Table 1.	ZHX1203 Transceiver Pin Out . . . . .	2
Table 2.	Absolute Maximum Ratings . . . . .	5
Table 3.	Recommended Operating Conditions . . . . .	5
Table 4.	Receiver Electrical Characteristics . . . . .	5
Table 5.	Transmitter Electrical Characteristics . . . . .	6
Table 6.	Transceiver Electrical Characteristics . . . . .	7

## Description

The ZILOG ZHX1203 for mobile phones, pagers, and PDAs is the smallest, lowest power, and highest functional transceiver in its class.

Communication takes place at the low receive current consumption of 100  $\mu\text{A}$  (typical). The ZHX1203MB features only the low receive current consumption of 100  $\mu\text{A}$  (typical).

The UltraSlim form factor (7.3 mm long x 2.8 mm wide x 1.9 mm high) allows placement in virtually any small device (see Figure 1). Application circuit space is also minimized because only two external components are required.



**Figure 1. UltraSlim Form**

The ZHX1203 is designed to support IrDA-Data SIR mode, which at 115 Kbits/s provides the capability for the user to share phone numbers, addresses, and notes as well as linking a PC to the internet via a mobile telephone.

The transceiver combines an IRED emitter, a photodiode, and a unique driver/control ASIC in a single package, as shown in Figure 2. The ZILOG ZHX1203 also features a shutdown control that minimizes current draw to 0.1  $\mu\text{A}$  typical.

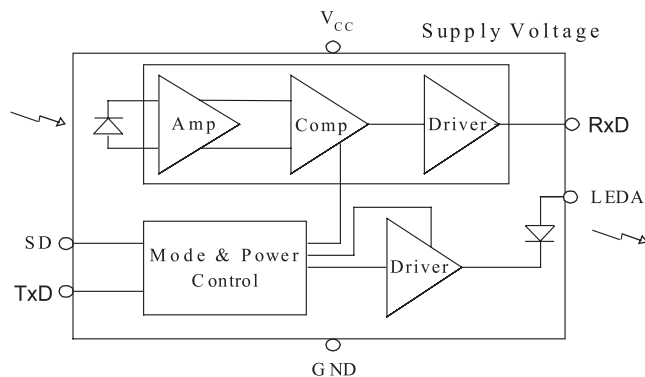

**Figure 2. ZHX1203 Block Diagram**

## Features

- Compliant to IrDA Data Specification 1.4 Low Power SIR (link range: low power to low power—0 to 20 cm; standard power to low power—0 to 30 cm)
- Low-power supply voltage range: 2.4 V to 3.6 V
- ZHX1203MB receive current: 100  $\mu$ A (typical)
- UltraSlim package: 7.3 mm long x 2.8 mm wide x 1.9 mm high
- Only two external components
- Extended operating temperature range:  $-30$  °C to  $+85$  °C
- Internal current source eliminates need for a current-limiting resistor for IR LED
- Meets IEC 825-1 Class 1 eye safety specifications

## Pin Description

Table 1 lists the pin out for the ZHX1203 transceiver. The pins are described in this section.

**Table 1. ZHX1203 Transceiver Pin Out**

Pin	Name	Function	I/O
1	NC	NC (future use)	—
2	V <sub>CC</sub>	Supply voltage	—
3	GND	Ground	—
4	SD	Shutdown	I
5	RxD	Receiver output	O
6	TxD	Transmitter input	I
7	LEDA	IRED anode	—
—	TAB	Shield connection	—

### V<sub>CC</sub> Positive Supply

(Power)

Connect to positive power supply (2.4–3.6 V). Filter with a 1.0- $\mu$ F ceramic bypass capacitor and terminating resistor as close as possible to the V<sub>CC</sub> pin.

## **GND Ground**

(Power)

Connect to ground of the power supply. A solid ground plane is recommended for proper operation.

## **SD Shutdown**

(Input, active high)

This input is used to place the IC into a shutdown mode.

TxD needs to be driven low to achieve low shutdown current and held low during the transition from shutdown to active to ensure that the circuitry is properly set to communicate.

## **RxD Receive Data**

(Output, active low)

This output provides received serial data. It is a tri-state, slew rate controlled CMOS output (tri-stated during shutdown) driver capable of driving a standard CMOS or LS series TTL load. No external resistor is required.

## **TxD Transmit Data**

(Input, active high)

This CMOS input is used to transmit serial data and has an internal pull-down resistor that is enabled only during shutdown.

## **LEDA LED Driver**

(Power)

This output is internally connected to the LED anode and contains an internal current source. The voltage range on this pad is 2.1–4.2 volts.

## **TAB Shield Connection**

The shield tab must be soldered to ground for proper operation.

## Application Block Diagrams

Figure 3 shows the application block diagrams for the ZHX1203 transceiver.

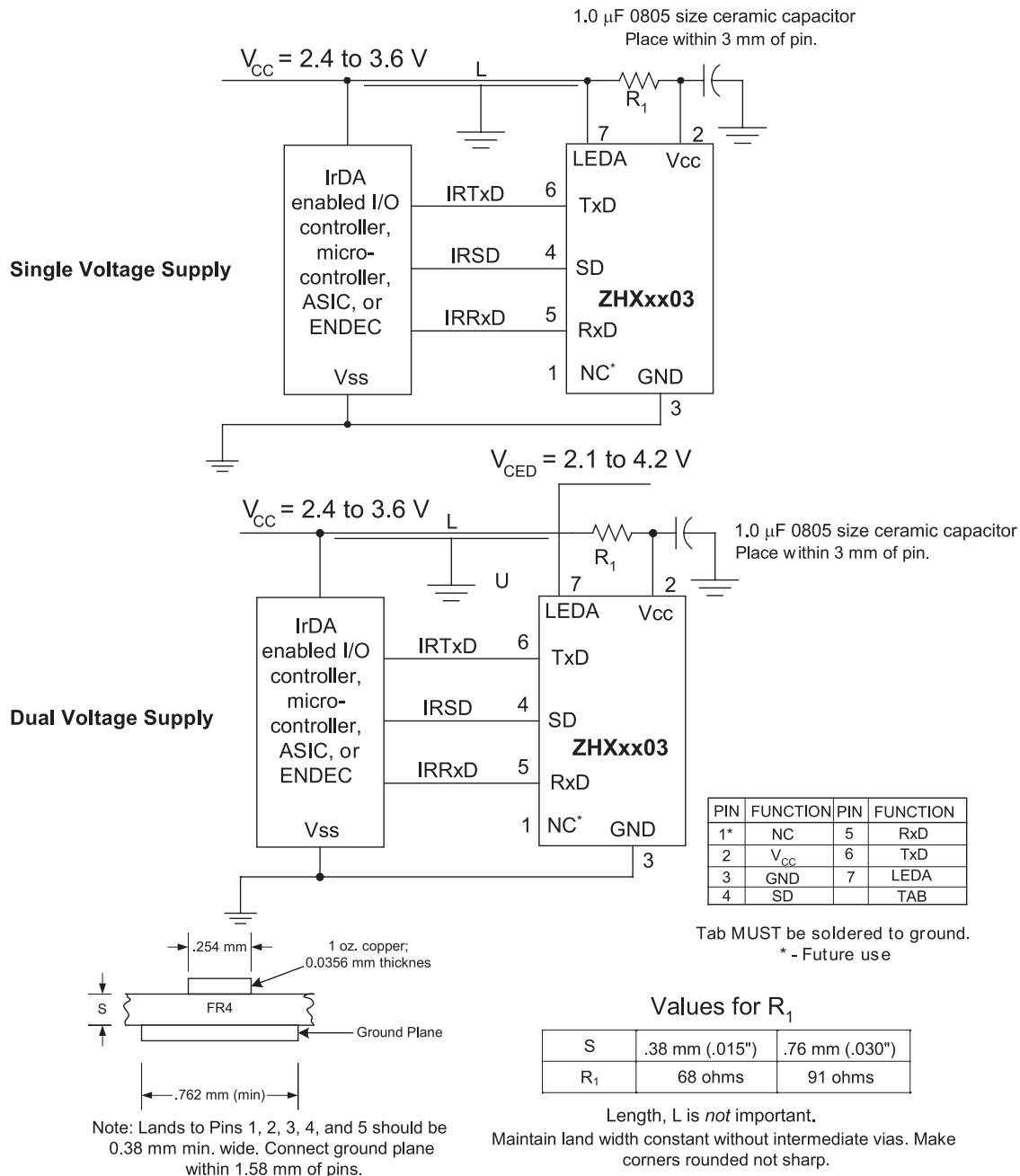

Figure 3. ZHX1203 Application Block Diagrams



## Electrical and Timing Specifications

Table 2 through Table 6 list the electrical and timing specifications.

**Table 2. Absolute Maximum Ratings**

Parameter	Symbol	Min	Max	Unit	Comment
Supply voltage	$V_{CC}$	-0.3	3.6	V	$V_{CC}$ , GND
Supply voltage	$V_{LED}$	-0.3	4.4	V	
Input voltage	$V_{IN}$	GND-0.3	$V_{CC}+0.3$	V	TxD, SD
Output (Ext.) voltage	$V_{OUT}$	GND-0.3	$V_{CC}+0.3$	V	RxD
Storage temperature	$T_{ST}$	-40	100	°C	
Solder temperature	$T_{SOL}$		240	°C	See page 9.
ESD			400	V	

**Table 3. Recommended Operating Conditions**

Parameter	Symbol	Min	Max	Unit
Supply voltage	$V_{CC}$	2.4	3.6	V
Supply voltage, LEDA	$V_{LED}$	2.1	4.2	V
Ambient operating temperature	$T_{OP}$	-30	85	°C

**Table 4. Receiver Electrical Characteristics**

Parameter	Symbol	Condition	Min	Typical	Max	Unit	Remarks
High-level output voltage	$V_{OH}$	$I_{OH}=-100\ \mu\text{A}$	$V_{CC}-0.4$			V	RxD
Low-level output voltage	$V_{OL}$	$I_{OL}=100\ \mu\text{A}$			0.4	V	RxD
RxD rise/fall time	$T_r, T_f$	$C_{load}=25\ \text{pF}$			100	ns	10% and 90%
RxD pulse width	$t_{PWA}$	$SIR \leq 115.2\ \text{Kbps}$		1	5	$\mu\text{s}$	Input pulse=1.6 $\mu\text{s}$ ; rise/fall time<600 ns
RxD pulse width, alternate 3/16 <sup>th</sup> of pulse duration. See IrDA Physical Layer specs.	$t_{PWA}$	$9.6 \leq SIR \leq 115.2\ \text{Kbps}$	TBD		TBD	$\mu\text{s}$	Input pulse=19.53 $\mu\text{s}$ (3/16*(1/9600))

**Table 4. Receiver Electrical Characteristics (Continued)**

Parameter	Symbol	Condition	Min	Typical	Max	Unit	Remarks
Startup time	$T_{STU}$			300		$\mu s$	
Latency	$T_{RRT}$			25	50	$\mu s$	
Minimum input irradiance	$E_{emin}$	$V_{CC}=3.3 V$			9	$\mu W/cm^2$	$\theta_h, \theta_v \leq (\pm 15^\circ)$
Maximum input irradiance	$E_{emax}$	$V_{CC}=3.3 V$			500	$mW/cm^2$	$\theta_h, \theta_v \leq (\pm 15^\circ)$
Logic low input irradiance	$E_{eL}$	$V_{CC}=3.3 V$			0.3	$\mu W/cm^2$	
Peak wavelength	$\lambda_p$			870		nm	

Unless otherwise noted:  $V_{CC}=3.3 V$ ,  $GND=0 V$ ,  $TA=25^\circ C$

**Table 5. Transmitter Electrical Characteristics**

Parameter	Symbol	Condition	Min	Typical	Max	Unit	Remarks
High-level input voltage	$V_{IH}$		$0.75V_{CC}$			V	TxD
Low-level input voltage	$V_{IL}$				0.4	V	TxD
Transmitter current	$I_{LED}$			40	65	mA	LEDA pin
Startup time	$T_{STU}$			20		$\mu s$	
LED protection timeout				130	270	$\mu s$	Protects LED when TxD is left high
Trans. radiant intensity	$I_E$		3.6		72	$mW/sr$	$\theta_h, \theta_v \leq (\pm 15^\circ)$
Peak wavelength	$\lambda_p$			870		nm	
Input leakage TxD pin	$I_{IL}$	$V_{IN}=0 V, V_{CC}$	-1		1	$\mu A$	
Optical pulse width	$t_{OW}$	9.6–115.2 kb/s		1.39	30	$\mu s$	
Optical rise time	$t_{OR}$	9.6–115.2 kb/s		100	600	$\mu s$	

**Table 5. Transmitter Electrical Characteristics (Continued)**

Parameter	Symbol	Condition	Min	Typical	Max	Unit	Remarks
Optical fall time	$t_{OF}$	9.6–115.2 kb/s		100	660	$\mu\text{s}$	
TxD pulldown resistor	$TxD_{RP}$	$SD=V_{CC}$	300K			$\Omega$	

Unless otherwise noted:  $V_{CC}=3.3\text{ V}$ ,  $GND=0\text{ V}$ ,  $TA=25\text{ }^\circ\text{C}$

**Table 6. Transceiver Electrical Characteristics**

Parameter	Symbol	Condition	Min	Typical	Max	Unit	Remarks
High-level input voltage	$V_{IH}$		$0.75V_{CC}$			V	SD
Low-level input voltage	$V_{IL}$				0.4	V	SD
Receive current	$I_{CC}$			100	125	$\mu\text{A}$	Idle
Shutdown current	$I_{STB}$			0.1	1.0	$\mu\text{A}$	$SD=V_{CC}$ , $TxD=0\text{ V}$
Power shutdown time	$T_{SD}$				200	$\mu\text{s}$	
Input leakage SD pin	$I_{IL}$	$V_{IN}=0\text{ V}$ , $V_{CC}$	-1		1	$\mu\text{A}$	
Transceiver data rate			9.6		115.2	kb/s	

Unless otherwise noted:  $V_{CC}=3.3\text{ V}$ ,  $GND=0\text{ V}$ ,  $TA=25\text{ }^\circ\text{C}$

- **Notes:** To minimize power dissipation, the part has been designed for optimal operation in 1.6  $\mu\text{s}$  mode. If the part is used in the 3/16<sup>th</sup> pulse duration mode, some devices might exhibit a phantom RxD pulse at 9.6 Kbits/s.

TxD *must* be held low during the transition from shutdown to active to ensure that the circuitry is properly set to communicate.



- Caution:** This component is susceptible to damage from electrostatic discharge (ESD). To prevent damage and/or degradation that might be induced by ESD, use normal static precautions in handling and assembly of this component.

## ZHX1203 Tape and Reel Specifications

Figure 4 shows the ZHX1203 reel specifications, and Figure 5 shows the ZHX1203 tape specifications.

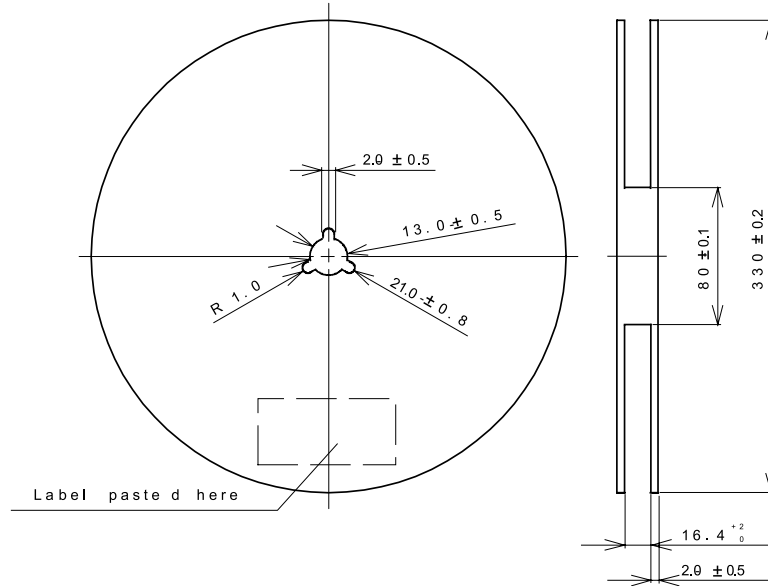

Figure 4. ZHX1203 Reel Specifications

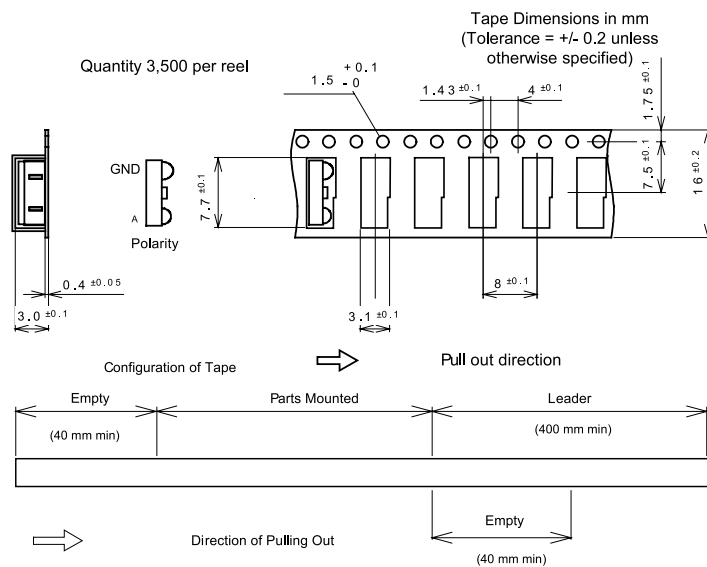

Figure 5. ZHX1203 Tape Specifications

## ZHX1203 Soldering and Cleaning Recommendations

Follow these recommendations to maintain the performance of the ZHX1203 transceiver.

### Reflow Soldering

- ▶ **Note:** Please refer to ZiLOG's Lead-Free Solder Reflow: Packaging Application Note (AN0161, <http://www.zilog.com/docstools.asp>) for more information about the solder profile.

### Manual Soldering

- Use 63/37 or silver solder.
- Temperature at solder iron tip: no more than 280 °C
- Finish soldering within 3 seconds.
- Handle only after the ZHX1203 has cooled off.

### Cleaning

Perform cleaning under the following conditions:

- Cleaning agent: alcohol
- Temperature and time 30 seconds below 50 °C or 3 minutes below 30 °C
- Ultrasonic cleaning: below 20 W

## Moisture Prevention Guidelines

To avoid moisture absorption during transportation and storage, ZHX1203 reels are packed in aluminum envelopes (see Figure 6) that contain a desiccant with a humidity indicator. While this packaging is an impediment to moisture absorption, it is by no means absolute, and no warranty is implied. The user must store these parts in a controlled environment to prevent moisture entry. Please read the label on the aluminum bag for indicator instructions.

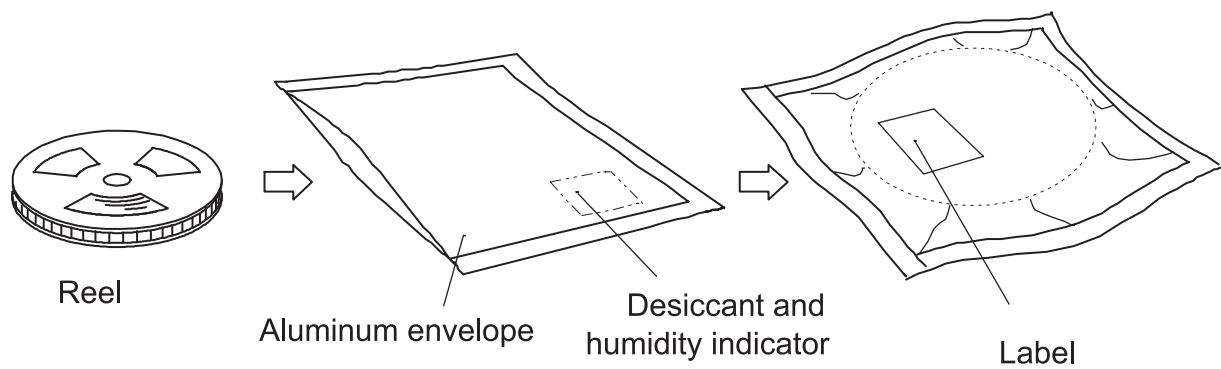

Figure 6. ZHX1203 Packaging

## Baking

It is recommended that parts that have been stored over 12 months or unpacked over 72 hours be baked under the following guidelines.

### Reels

60 °C for 48 hours or more

### Loose Parts

- 100 °C for 4 hours or more  
or
- 125 °C for 2 hours or more  
or
- 150 °C for 1 hour or more

# Mechanical Drawing

Figure 7 shows the mechanical specification for the ZHX1203 transceiver.

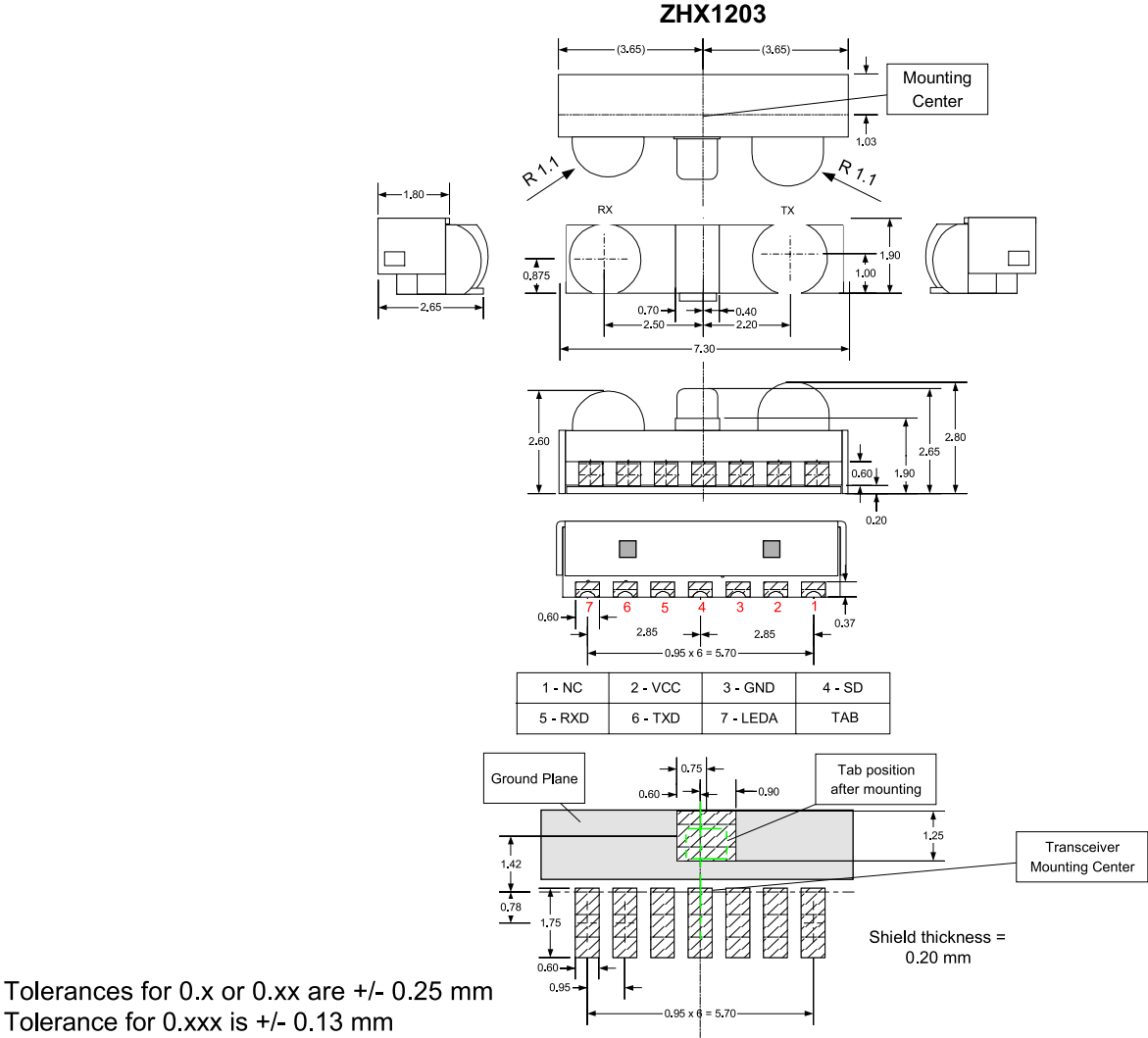

Figure 7. ZHX1203 Mechanical Drawing

► **Note:** The ZHX1203 family of transceivers are marked as follows:  
ZHX1203MB = Z1203



## Ordering Information

Use the following information to order the ZHX1203 transceiver:

ZHX1203MB115THTR without AlwaysOn Listen      3500 per reel

- ▶ **Note:** All ZiLOG devices are available lead free. Since 2005, ZHX1203 has been manufactured with lead-free components. When ordering from your ZiLOG distributor, there is a possibility that the parts containing lead might be shipped. To ensure that you receive lead-free devices, please use part number ZHX1203MB115TH2090TR. These devices meet or exceed RoHS Directive 2002/95/EC. For additional information, please see the ZiLOG Quality and Reliability web page at <http://www.zilog.com/quality/index.asp>.





## Customer Feedback Form

If you experience any problems while operating the ZHX1203 transceiver, or if you note any inaccuracies while reading this product specification, please copy and complete this form, then mail or fax it to ZiLOG (see "Return Information," below). We also welcome your suggestions!

### Customer Information

Name	Country
Company	Phone
Address	Fax
City/State/Zip	email

### Product Information

Serial # or Board Fab #/Rev #
Software Version
Document Number
Host Computer Description/Type

### Return Information

ZiLOG  
System Test/Customer Support  
532 Race Street  
San Jose, CA 95126-3432  
Fax: (408) 558-8300  
Web: [www.zilog.com](http://www.zilog.com)

### Problem Description or Suggestion

Provide a complete description of the problem or your suggestion. If you are reporting a specific problem, include all steps leading up to the occurrence of the problem. Attach additional pages as necessary.

---

---

---

---